

**ARE YOU PREPARED TO
RISK THE ALTERNATIVE?**



BACKFLOW PREVENTION

Prime
Composites Aust P/L

Mission Statement:

It is the mission of Prime Composites Aust P/L to continually develop new products and manufacturing processes and to become the only place to go for backflow prevention solutions for large pipes and box culverts.

Intention:

It is the intention of Prime Composites Aust P/L to create a positive memorable experience each and every time with every contact, whether customer, supplier or team member.

Vision:

It is the vision of Prime Composites Aust P/L to become the one stop backflow prevention shop for large pipes and box culverts.

Prime Composites Australia P/L is located at Arundel on the Gold Coast.

We are a family owned and operated small business, so we are able to offer old fashioned customer service and backup, and take the time to listen to our customers.

We have been at the forefront of manufacturing and supply of quality fibreglass floodgates for more than four decades.

Prime floodgates are a non-return valve used extensively around Australia and internationally, and are regularly specified by water authorities, councils and engineers.

Prime floodgates are also known as King Valves, reflux valves, tidal flaps, gas checks and croc stops.

Prime floodgates are the most popular end of line backflow prevention device used in Australia on large diameter pipes and box culverts.

Application:

Prevents tidal inundation.

Ideal for reclamation of low lying areas.

Prevents children from entering dangerous stormwater lines.

Prevents the entry of animals and vermin.

Construction:

All Prime floodgates are produced from high quality fibreglass materials and are fitted with neoprene seals as standard (other materials are available for different applications)

The use of 316 grade stainless steel or bronze hinge pins make Prime floodgates suitable for the most demanding environments.

Advantages:

Excellent resistance to sea water, sewage and a wide range of chemicals.

Extremely durable.

UV stable.

Quick and easy to install.

Cost effective.

Due to the pin location on all our gates, they will seal effectively when fitted to the normal vertical end of the pipe.

Because they are fibreglass and have only small metal components they do not have any scrap value.

We have several different attachment methods for our floodgates:-

Ring Mount

Our ring mount floodgate is fitted to a collar via a hinge.

The collar slides over the end of the pipe and is epoxied in place making it quick and easy to install.

A neoprene seal is embedded into the face of the mounting ring, and worked to fine tolerances in the final stages of production, the flap seats against the seal.

Wall Mount

Our Wall Mount floodgate is very similar to the ring mount floodgate but has been fitted with a flange which is bolted to the wall.

This unit is ideal for installation onto pit walls and headwalls.

Scour Valve

Our scour valve is very similar to the wall mount, the difference is that the scour flange is drilled to specific bolt patterns to match flanged metal pipes.

Bolt On Type

Our bolt on floodgates have a neoprene seal embedded into the face of the flap; this seal contacts the face of the pipe to create a seal.

As the name suggests this unit bolts onto the top of the pipe.

We can also produce square and rectangular units to suit box culverts in wall mounts and bolt on type.

Due to the material selection, our gates will operate in the most demanding environments.

Ring Mount Floodgates



2 x 600 ring mount, Coombabah Creek, Gold Coast

FLOODGATE DIMENSION CHART (RING MOUNT) 100 - 900													
NB	RC/VC PIPE			PVC PIPE			DI PIPE			FRC PIPE			HEAD TO OPEN mm
	A	B	C	A	B	C	A	B	C	A	B	C	
100	150	160	30	120	130	30	125	130	30	135	160	30	45
150	200	210	30	165	195	30	180	195	30	195	210	30	45
200	---	---	---	230	250	30	---	---	---	---	---	---	55
225	280	300	40	255	275	40	270	275	40	280	300	40	80
250	---	---	---	290	305	40	---	---	---	---	---	---	80
300	370	390	50	325	390	50	350	390	50	370	390	50	75
375	450	475	50	410	480	50	440	475	50	450	475	50	95
450	540	560	50	510	525	50	520	560	50	540	560	50	105
525	625	650	50	---	---	---	600	650	50	625	650	50	60
600	710	730	50	---	---	---	680	730	50	710	730	50	90
675	790	815	50	---	---	---	760	815	50	775	815	50	100
750	875	905	50	---	---	---	840	905	50	855	905	50	110
825	955	985	50	---	---	---	920	985	50	---	---	---	120
900	1035	1065	55	---	---	---	1000	1065	55	---	---	---	150

Floodgates to suit other types of pipes are available on request

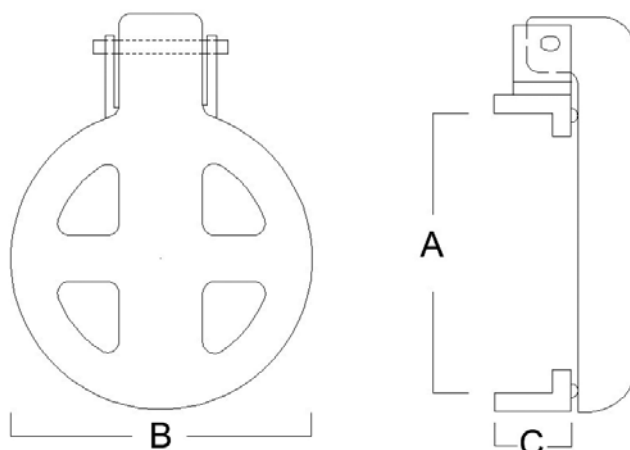

Large Floodgate Ring Mount



1350 ring mount, Mackay, Qld

FLOODGATE DIMENSION CHART(RING MOUNT)1050 - 1800					
NB	A	B	C	Approx Flap Weight kg	Head required to open (mm)
1050	350	1240	1210	130	270
1200	350	1420	1390	200	310
1350	350	1575	1545	210	390
1500	300	1745	1715	300	225
1650	300	1920	1890	440	255
1800	300	2075	2045	620	300

* Dimensions are nominal only

1050-1350

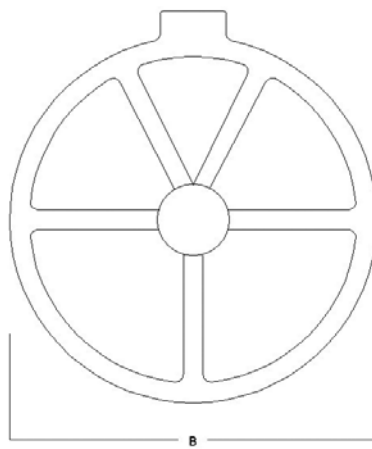

1500-1800

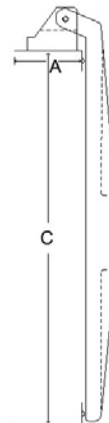
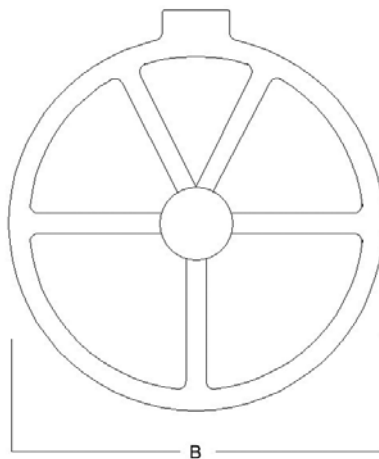

Low Head Floodgate (Ring Mount)

100-900



Ideal for use where there is a low flow or flat grade, or sewer systems where less restriction is required. The flap will open sooner than the standard Prime Heavy Duty flap, minimising backup.

Available in sizes up to 900mm.

Hinge type and colour of product may change without notice.

RING MOUNT FLOODGATE INSTALLATION

INSTALLATION:

- 1) Make sure the inside of the mounting ring is clean and dry.
- 2) Mix together the epoxy adhesive (supplied) in containers marked A and B. Continue to mix until an even colour is achieved.
- 3) Apply an even coating of the mixture to the inside of the mounting ring.
- 4) With the hinge at top centre, press the ring and flap assembly firmly onto the pipe end. Allow 24 hours for the adhesive to cure.

Two people may be required for gates larger than 600mm.

Do not remove ring from flap.

Do not apply pressure to hold the gate onto the pipe during installation.

When fitting to HDPE pipe, we recommend that the end 70mm of the pipe be grooved to allow a mechanical bond rather than a chemical bond due to the characteristics of HDPE.

HANDLING:

- 1) During transit and storage the gate must be laid flat on an even surface or distortion of the gate may occur. (This is not a concern once the gate is fitted to the pipe)

RECOMMENDATIONS:

- * Where floodgates could be damaged by floating debris or severe wave action we recommend it be protected by a headwall or pit.
- * We recommend a minimum drop below the bottom of the floodgate of 300mm to allow debris discharge to clear the floodgate, this will also help prevent the build up of silt which will foul the operation.
- * As with any product, **PRIME** ring mount floodgates need to be checked and maintained regularly to ensure correct operation and to prolong the life of the gate. (The only maintenance required is to keep the area around the gate free of debris and silt.)

Outside diameter of pipe should be stated when ordering.

100-900 Wall Mount



2 x 750 wall mount, Blacktown, NSW

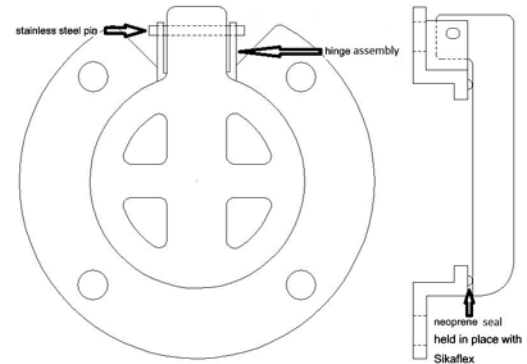
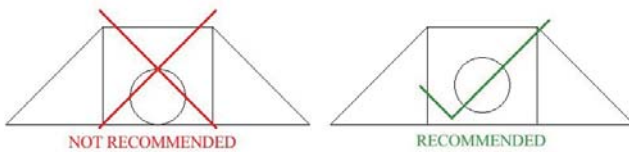

We recommend that the hole in the headwall be raised the distance shown on the chart to allow for the flange at the base, or the assembly may affect the flow characteristics.

This will also minimise silt and debris collection.

**FLOODGATE DIMENSION CHART
(100-900 WALL MOUNT)**

SIZE (NB)	FLANGE DIA	BOLT CENTRES	HEAD REQUIRED TO OPEN (APPROX)mm	APPROX WEIGHT KG	RAISE HOLE BY mm
100	215	180	45	1	60
150	310	260	45	2	80
200	350	300	55	5	80
225	400	350	80	6	110
250	405	355	80	7	110
300	540	465	75	10	120
375	625	550	95	15	125
450	710	635	105	25	130
525	800	725	60	30	140
600	880	805	90	40	140
675	965	890	100	50	145
750	1055	980	110	70	150
825	1150	1060	120	75	160
900	1215	1140	150	100	160

NOTE: Dimensions are approximate only

1050-1800 Wall Mount Floodgate



2 x 1500 wall mount, Sydney, NSW

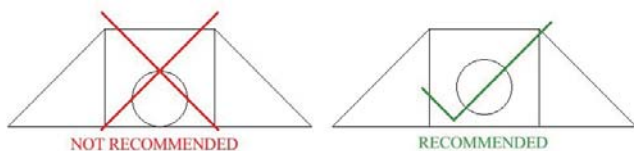

We recommend that the hole in the headwall be raised the distance shown on the chart to allow for the flange at the base, or the assembly may affect the flow characteristics. This will also minimise silt and debris collection.

FLOODGATE DIMENSION CHART (1050-1800 WALL MOUNT)					
NB	FLANGE DIA	HOLES @ DIA	Weight (approx) kg	Head required to open (mm)	Raise Hole by
1050	1385	9 @ 18mm	250	270	170
1200	1565	9 @ 18mm	400	310	180
1350	1720	9 @ 18mm	420	390	185
1500	1890	11 @ 18mm	550	225	195
1650	2065	13 @ 18mm	850	255	210
1800	2220	13 @ 18mm	1200	300	210

Fasteners are not included

1050-1350 Wall Mount

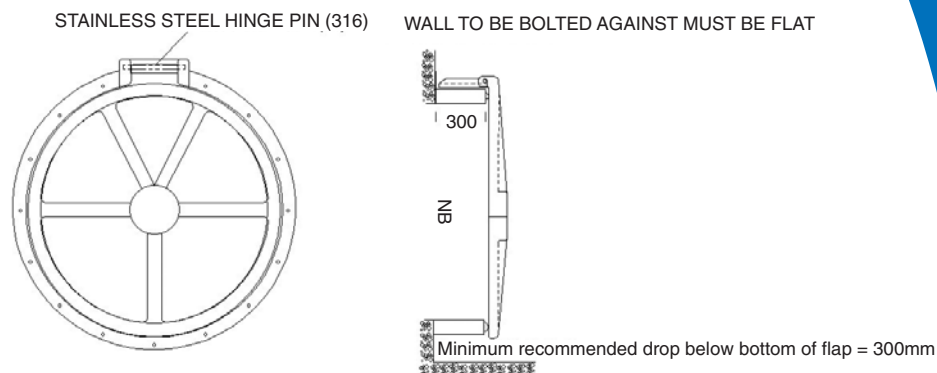

1500-1800 Wall Mount

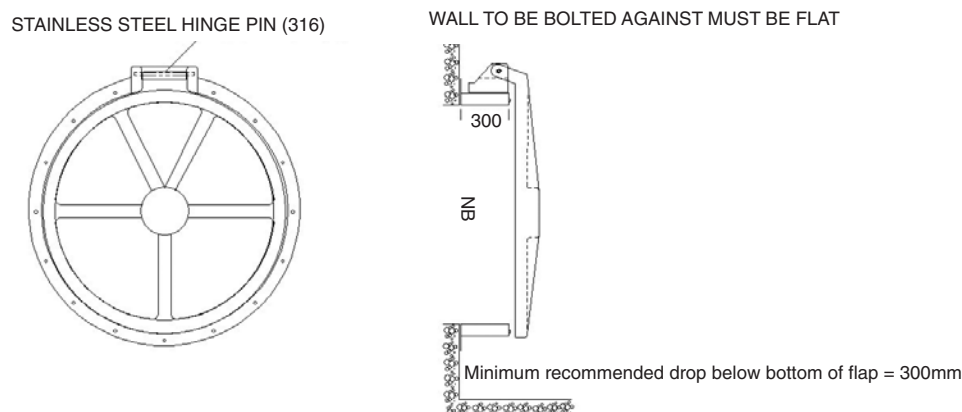

INSTALLATION OF WALL MOUNT FLOODGATES

- 1) Ensure wall is flat or distortion of the mounting ring will result.
- 2) Hold the floodgate against the wall and mark through holes in flange. (Two people may be required)
- 3) Remove floodgate and drill holes into wall to suit chosen fasteners.
- 4) Apply a bead of sealant to the entire circumference of the mounting flange.
- 5) Hold floodgate against the wall and do up fasteners.

(DO NOT OVERTIGHTEN FASTENERS)

Two people may be required for gates larger than 600mm.

Do not remove ring from flap.

NOTE: Fasteners not supplied.

HANDLING:

- 1) During transit and storage the gate must be laid flat on an even surface or distortion of the gate may occur. (This is not a concern once the gate is fitted to the wall)

RECOMMENDATIONS:

- * We recommend a minimum drop below the bottom of the floodgate of 300mm to allow debris discharge to clear the floodgate. This will also help prevent the build up of silt which will foul the operation.
- * As with any product, **PRIME** wall mount floodgates need to be checked and maintained regularly to ensure correct operation and to prolong the life of the gate. (The only maintenance required is to keep the area around the gate free of debris and silt.)

Integrated Security Bars

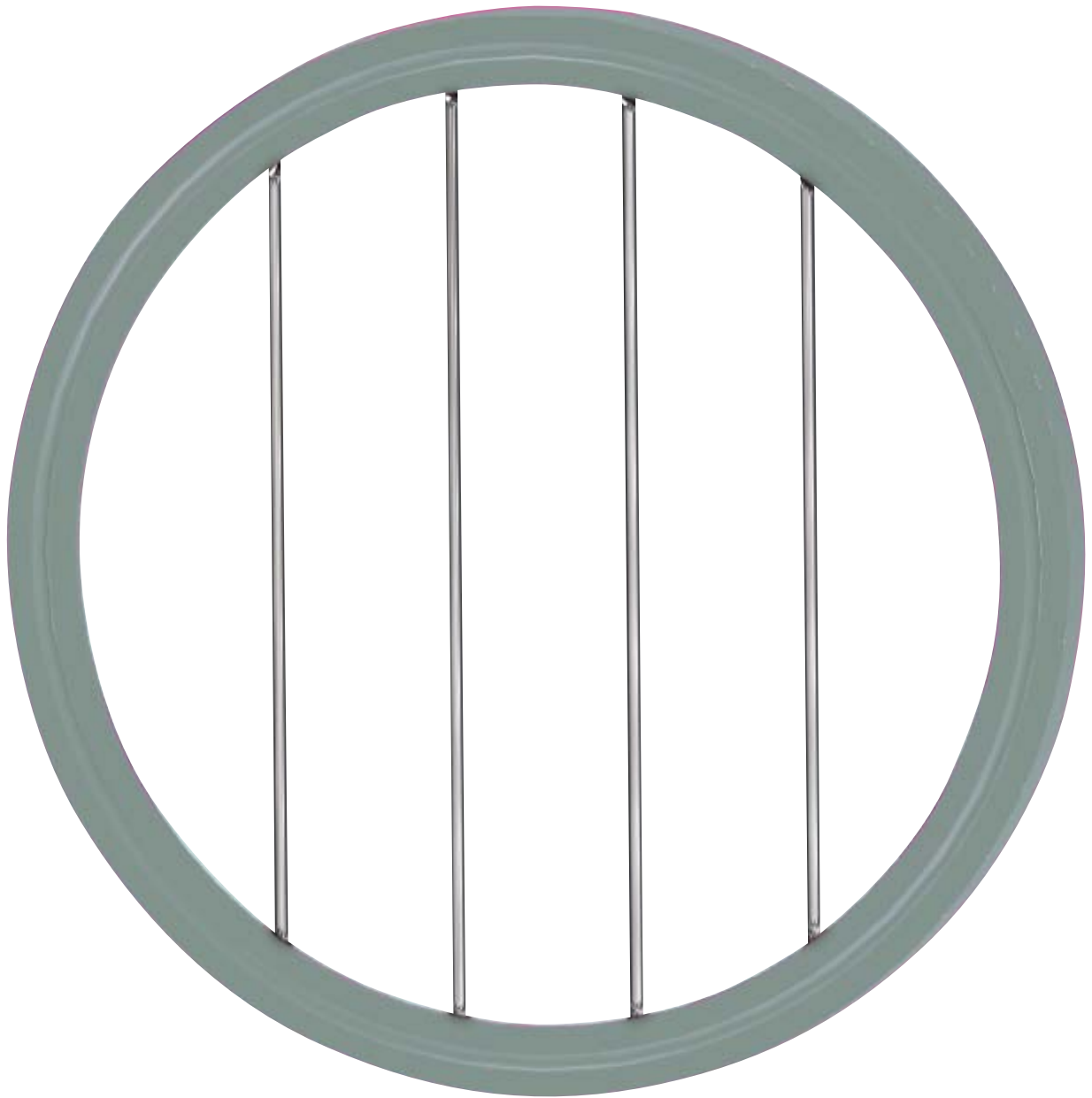

Ideal for use where security is paramount.

Can be adhered to pipe as a stand alone unit or bars can be integrated into the standard floodgate mounting ring or wall mount structure making it a more cost effective solution.

CONSTRUCTION: High quality fibreglass materials

BARS: 316 grade stainless steel

SIZES: 225 to 1800 diam

Bolt on Top of Pipe Series



1050 bolt on, Coomera River, Gold Coast



3 x 1500 bolt on, 19th Avenue, Elanora, Gold Coast

FLOODGATE DIMENSION CHART (BOLT ON) 1050-1800				
NB	A	B	Weight (approx) kg	Head required to open (mm)
1050	330	1185	130	270
1200	330	1365	200	310
1350	330	1520	210	390
1500	260	1690	300	225
1650	260	1865	440	255
1800	260	2020	620	300

* Dimensions are nominal only

1050-1350 Bolt On

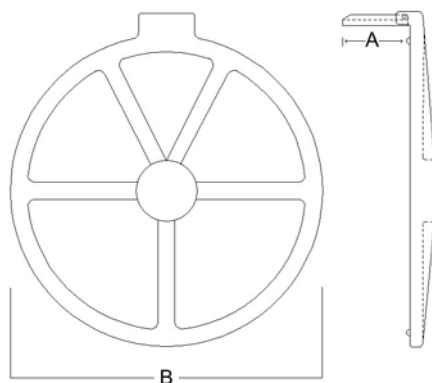

1500-1800 Bolt On

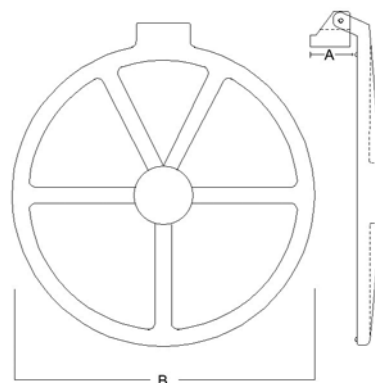

Low Internal Head Floodgate (Bolt on Type) 100-900



2 x 825 bolt on, Marina Mirage, Gold Coast

Ideal for use where there is a low flow or flat grade, or in sewer systems where less restriction is required. The flap will open sooner than the standard Prime Heavy Duty flap, minimising backup.

Also suitable for installing when ring mount type is not practical, due to water level that doesn't allow the use of adhesives to attach the standard ring mount type.

To achieve optimum seal the face of the pipe must be clean and flat.

Available in 100-900 bolt on, ring mount, and wall mount

Hinge type and colour of product may change without notice.

INSTALLATION: Bolt on Type

- 1) Check that the face of the pipe is flat.
- 2) Place the floodgate on the pipe to ensure it fits correctly. Mechanical lifting equipment will be required on larger gates.
- 3) With the hinge on the top of the pipe, drill through the hinge and the top of the pipe.
- 4) Attach with chosen fasteners.

NOTE: Fasteners not supplied.

CAUTION: Confined spaces procedures should be followed if entry to the pipe is necessary to tighten fasteners

HANDLING:

- 1) During transit and storage the gate must be laid flat on an even surface or distortion of the gate may occur. (This is not a concern once the gate is fitted to the pipe)

RECOMMENDATIONS:

- * Where floodgates could be damaged by floating debris or severe wave action, we recommend it be protected by a headwall or pit.
- * We recommend a minimum drop below the bottom of the floodgate of 300mm to allow debris discharge to clear the floodgate, this will also help prevent the build up of silt which will foul the operation.
- * As with any product, **PRIME** bolt on floodgates need to be checked and maintained regularly to ensure correct operation and to prolong the life of the gate. (The only maintenance required is to keep the area around the gate free of debris and silt.)
- * The pipe face must be flat if a seal is expected.
- * Packing may be required under the hinge in some cases.

100-375 Suit Scour Application



100 Table C/D

100-375 Suit Scour Application

Nominal Size

Table C/D	100	150	200	225	250	300	375
Flange diameter	215	280	335	370	405	455	550
PCD	178	235	292	324	356	406	495
Diameter of holes	18	18	18	18	22	22	26
No. of holes	4	8	8	8	8	12	12

Table F/H	100	150	200	225	250	300	375
Flange diameter	230	305	370	405	430	490	580
PCD	191	260	324	356	381	438	521
Diameter of holes	18	22	22	26	26	26	30
No. of holes	8	12	12	12	12	16	16

Table E	100	150	200	225	250	300	375
Flange diameter	215	280	335	370	405	455	550
PCD	178	235	292	324	356	406	495
Diameter of holes	18	22	22	22	22	26	26
No. of holes	8	8	8	12	12	12	12

Other flange sizes and bolt patterns are available on request

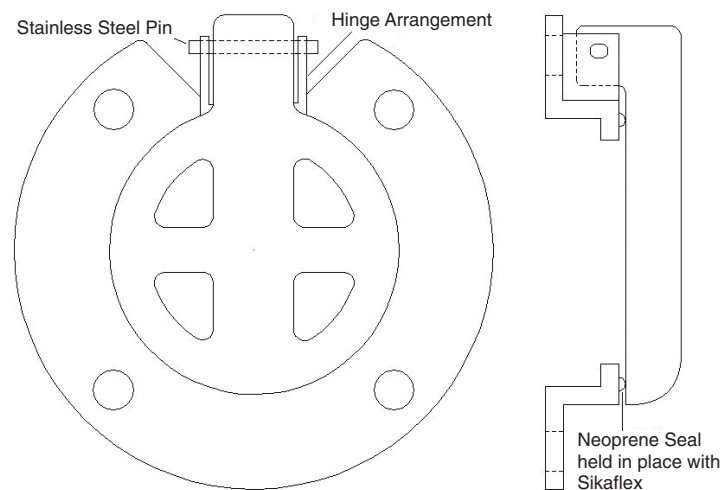

Performance Data

External Head (static)

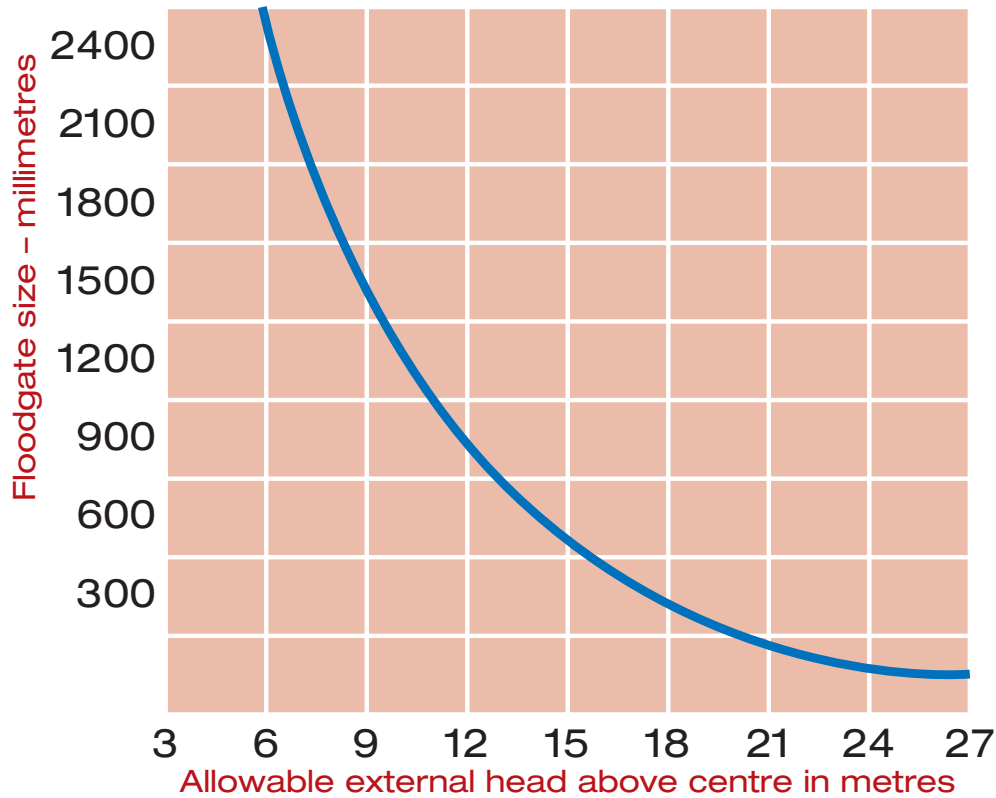

Head Loss

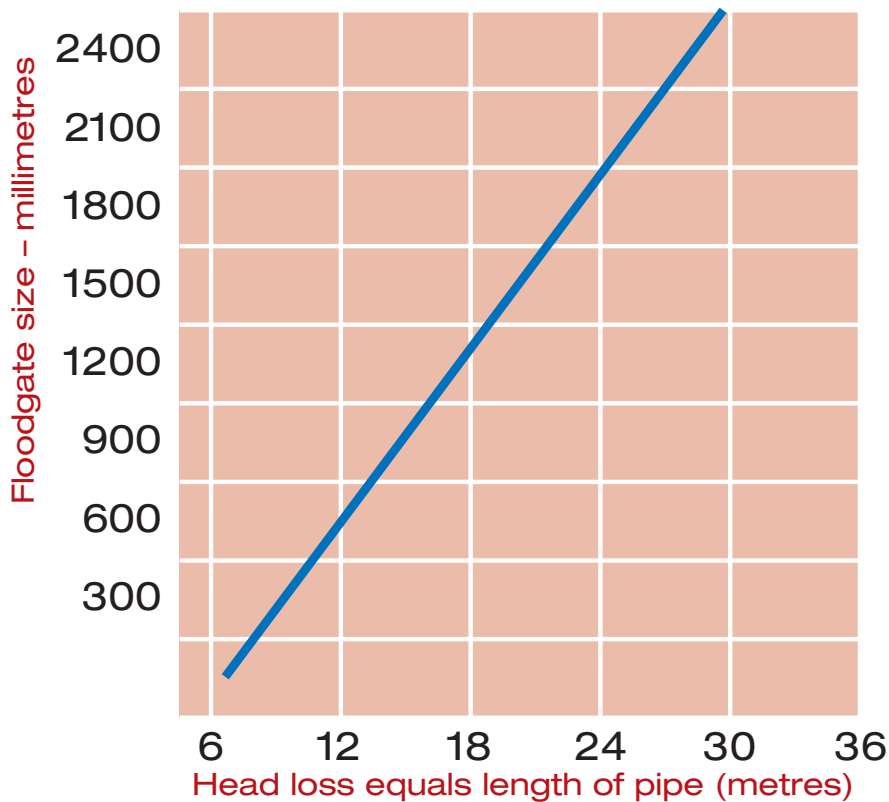

The above table shows head loss e.g. the head loss caused by a 600 diam. floodgate would be similar to the head loss of approx. 12 metres of 600 diam. pipe.

The head loss caused by a 1800 diam. floodgate would be similar to the head loss of approx. 24 metres of 1800 diam. pipe.

Small Box Culvert Floodgate



4 x 1200 x 375 installed at Eagle Mount Heights, Mackay, Qld

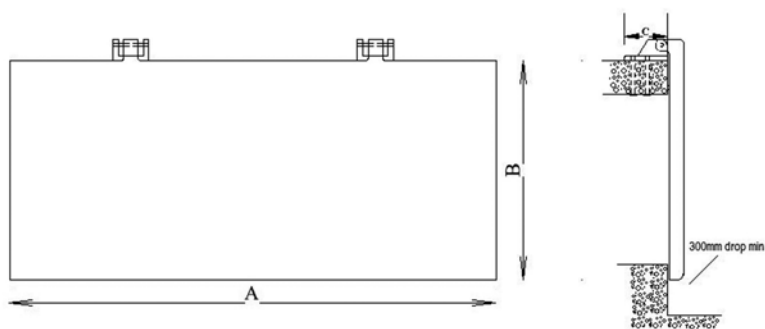

Hinge type, quantity and colour of product may change without notice

Wall mount also available

Nominal size	A mm	B mm	C mm
300 x 150	450	310	150
x 225	450	385	150
x 300	450	460	150
375 x 150	520	310	150
x 225	520	385	150
x 300	520	460	150
x 375	520	540	150
450 x 150	600	310	150
x 225	600	385	150
x 300	600	460	150
x 375	600	540	150
x 450	600	610	150
600 x 150	760	310	150
x 225	760	385	150
x 300	760	460	150
x 375	760	540	150
x 450	760	610	150
x 600	760	770	150
750 x 150	920	310	150
x 225	920	385	150
x 300	920	460	150
x 375	920	540	150
x 450	920	610	150
x 600	920	770	150
x 750	920	920	150
900 x 150	1075	310	150
x 225	1075	385	150
x 300	1075	460	150
x 375	1075	540	150
x 450	1075	610	150
x 600	1075	770	150
x 750	1075	920	150
x 900	1075	1075	150
1050 x 150	1235	310	150
x 225	1235	385	150
x 300	1235	460	150
x 375	1235	540	150
x 450	1235	610	150
x 600	1235	770	150
x 750	1235	920	150
x 900	1235	1075	150
x 1050	1235	1235	150
1200 x 150	1395	310	150
x 225	1395	385	150
x 300	1395	460	150
x 375	1395	540	150
x 450	1395	610	150
x 600	1395	770	150
x 750	1395	920	150
x 900	1395	1075	150
x 1050	1395	1235	150
x 1200	1395	1395	150

Dimensions are nominal

Other sizes are available on request

Please state actual culvert dimensions when ordering.

Large Box Culvert Floodgate



2 x 1800 x 1200, Mackay Qld

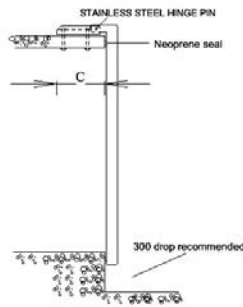
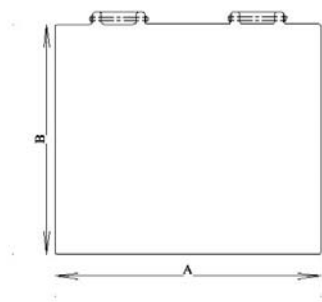

Hinge type, quantity and colour of product may change without notice

Wall mount also available

Nominal size	A mm	B mm	C mm
1500 x 300	1735	525	350
x 450	1740	680	350
x 600	1750	830	350
x 750	1755	980	350
x 900	1760	1140	350
x 1200	1775	1445	350
x 1500	1790	1750	350
1800 x 300	2040	525	350
x 450	2050	680	350
x 600	2055	830	350
x 750	2060	980	350
x 900	2070	1140	350
x 1200	2080	1445	350
x 1500	2090	1750	350
x 1800	2105	2055	350
2100 x 300	2345	525	350
x 450	2350	680	350
x 600	2360	830	350
x 750	2365	980	350
x 900	2370	1140	350
x 1200	2385	1445	350
x 1500	2400	1750	350
x 1800	2410	2055	350
x 2100	2420	2360	350
2400 x 450	2655	680	350
x 600	2665	830	350
x 750	2670	980	350
x 900	2680	1140	350
x 1200	2690	1445	350
x 1500	2700	1750	350
x 1800	2715	2055	350
x 2100	2725	2360	350
x 2400	2740	2675	350
2700 x 600	2970	830	350
x 750	2975	980	350
x 900	2980	1140	350
x 1200	2990	1445	350
x 1500	3010	1750	350
x 1800	3020	2055	350
x 2100	3030	2360	350
x 2400	3045	2675	350
x 2700	3060	2995	350

Dimensions are nominal

Other sizes are available on request

Please state actual culvert dimensions when ordering.

Rubber Duckbill Check Valves (Clamp On)

APPLICATION:

Prime collar mount rubber duckbill check valves are a non return valve used extensively around Australia and internationally, and are regularly specified by water authorities, councils and design engineers for use in sewage treatment plants, ocean outfalls, and as tidal inundation prevention.

- * Prevents children from entering dangerous stormwater lines
- * Prevents backflow
- * Ideal for reclamation of low lying areas
- * Prevents the entry of animals and vermin

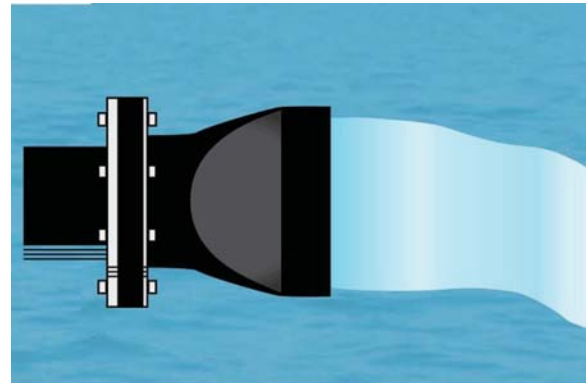

ADVANTAGES:

- * Excellent resistance to sea water, sewage, and a wide range of chemicals
- * Extremely durable
- * UV stable
- * Quick and easy to install
- * All rubber construction resists abrasive slurries
- * Quiet operation, ideal for residential areas
- * No water hammer
- * Can be installed on any gradient of pipe
- * Cost effective

If chemical contact is expected, please advise in the first instance

SPECIFICATION:

- * Produced from a large range of rubber compounds to withstand the most demanding situations
- * Supplied with Stainless Steel clamps
- * 35 year design life

INSTALLATION:

- 1) Measure ID of rubber check valve to ensure correct size has been supplied. The ID of the check valve should be as close as possible to the OD of the pipe.
- 2) Pipe must be free of sharp edges to avoid valve damage.
- 3) Apply soapy water to outside of pipe prior to installation. This will help slide the check valve onto the pipe.
- 4) With the bill vertical, fix clamp/s, if more than one clamp has been supplied fix the second clamp at 90 degrees to the first to ensure even pressure is applied to the valve. Make sure clamp bolts are accessible for easy tightening.
- 5) Once the clamps are tightened drill a hole/s through the centre hole on the clamp/s right through the pipe wall.
- 6) Insert a suitable size and length stainless steel bolt/s into the hole/s so they go the depth of the pipe wall
- 7) Weld bolt head/s to the clamp/s, this will anchor the valve to the pipe and ensure zero slippage

HANDLING:

- 1) Lifting equipment is recommended.

RECOMMENDATIONS:

- * Where there are abnormal currents or severe wave action we recommend it be protected by a headwall or pit.
- * The Primeflex rubber duckbill check valve should be installed with the bill vertical, however if bottom clearance is an issue, the valve may be installed with the bill rotated up to 30 degrees
- * As with any product, **PRIMEFLEX** rubber duckbill check valves need to be checked and maintained regularly to ensure correct operation and prolong the life of the valve. (The only maintenance required is to inspect the bill for trapped debris.)

Outside diameter of pipe should be stated when ordering.

Internal and external head should be stated when ordering.

SIZES:

PRIMEFLEX rubber duckbill check valves can be produced to suit any size and type of pipe up to 1800mm dia
Units are available to suit flanged pipes as well as in line installations.

Rubber Duckbill Check Valves (Clamp On)

NB	LENGTH	CUFF WIDTH	DUCKBILL HEIGHT	APPROX WEIGHT
25	100	25	55	1.0
40	130	25	70	1.8
50	165	40	100	2.3
65	190	50	120	3.6
80	215	75	140	5.0
100	305	75	190	6.8
125	355	75	220	7.7
150	405	100	270	9.5
200	430	100	350	11.3
250	480	100	430	17
300	635	150	500	25
350	690	150	630	33
400	740	150	657	55
450	790	150	755	90
500	840	200	800	140
600	1065	200	1090	175
700	1120	200	1170	200
750	1170	250	1250	240
800	1350	250	1295	265
900	1470	250	1400	280
1050	1550	305	1680	410
1200	1830	305	1890	430
1350	1880	305	1990	450
1500	2060	305	2160	550
1800	2490	360	2670	620

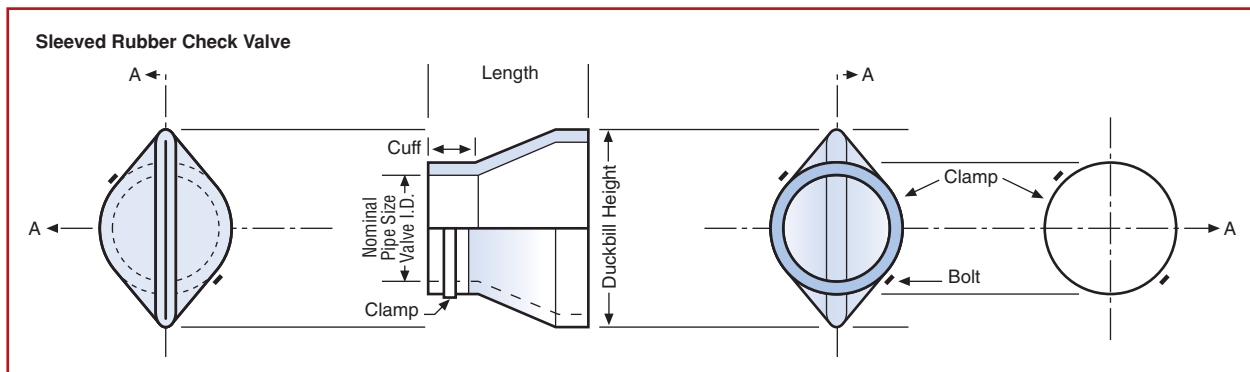

Rubber Duckbill Check Valves (Flanged)

APPLICATION:

Prime flanged rubber duckbill check valves are a non return valve used extensively around Australia and internationally, and are regularly specified by water authorities, councils, and design engineers for use in sewage treatment plants, chemical plants, ocean outfalls, and as tidal inundation prevention.

- * Prevents children from entering dangerous stormwater lines
- * Prevents backflow
- * Ideal for reclamation of low lying areas
- * Prevents the entry of animals and vermin

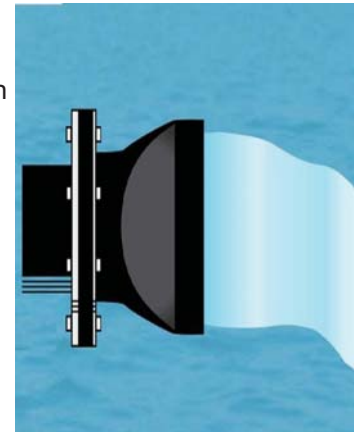
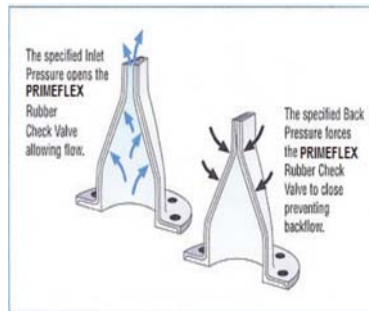

ADVANTAGES:

- * Excellent resistance to sea water, sewage, and a wide range of chemicals
- * Extremely durable
- * UV stable
- * Quick and easy to install
- * All rubber construction resists abrasive slurries
- * Quiet operation, ideal for residential areas
- * No water hammer
- * Can be installed on any gradient of pipe
- * Cost effective

#If chemical contact is expected, please advise in the first instance

SPECIFICATION:

- * Produced from a large range of rubber compounds to withstand the most demanding all situations
- * Supplied with Stainless Steel backing plate
- * **35 year design life**

INSTALLATION: Flanged

- 1) Measure ID of rubber check valve and OD of flange to ensure correct size has been supplied,
- 2) With the bill vertical, attach check valve to pipe flange using stainless steel bolts(not supplied)
- 3) Tighten bolts in a criss-cross pattern until the rubber flange bulges slightly,which will ensure proper crush on the flange sealing face.

HANDLING:

- 1) Lifting equipment is recommended.

RECOMMENDATIONS:

- * Where there are abnormal currents or severe wave action we recommend it be protected by a headwall or pit.
- * The Primeflex rubber duckbill check valve should be installed with the bill vertical, however if bottom clearance is an issue the valve may be installed with the bill rotated up to 30 degrees
- * As with any product, **PRIMEFLEX** rubber duckbill check valves need to be checked and maintained regularly to ensure correct operation and to prolong the life of the valve (The only maintenance required is to inspect the bill for trapped debris.)

Outside and inside diameter of pipe should be stated when ordering.

Internal and external head should be stated when ordering.

Bolt pattern must be stated when ordering

SIZES:

PRIMEFLEX rubber duckbill check valves can be produced to suit most bolt patterns of most sizes and type of pipe up to 1800mm dia

Units are available to suit end of pipes as well as in line installations.

Rubber Duckbill Check Valves (Flanged)

NB	Standard Dimensions		Standard Drilling		
	LENGTH	DUCKBILL HEIGHT	FLANGE OD	No. OF HOLES	APPROX WEIGHT
25	100	55	108	4	1.5
40	130	70	127	4	2.0
50	165	100	152	4	3.0
65	190	120	178	4	4.0
80	215	140	190	4	5.0
100	250	190	228	8	6.5
125	305	220	254	8	8.0
150	330	270	280	8	10.0
200	380	350	343	8	12.0
250	425	430	406	12	18.0
300	480	500	482	12	28.0
350	530	630	533	12	37.0
400	610	670	596	16	57.0
450	660	755	635	16	95.0
500	815	800	698	20	140.0
600	1070	1090	812	20	185.0
700	1145	1170	927	28	220.0
750	1195	1250	984	28	250.0
800	1350	1295	1060	28	275.0
900	1470	1400	1168	32	300.0
1050	1575	1680	1345	36	440.0
1200	1830	1890	1511	44	455.0
1350	1880	1990	1682	44	490.0
1500	2080	2160	1855	52	580.0
1800	2490	2670	2200	60	680.0

Dimensions are approximate only

A large selection of bolt patterns and flange diameters are available on request.

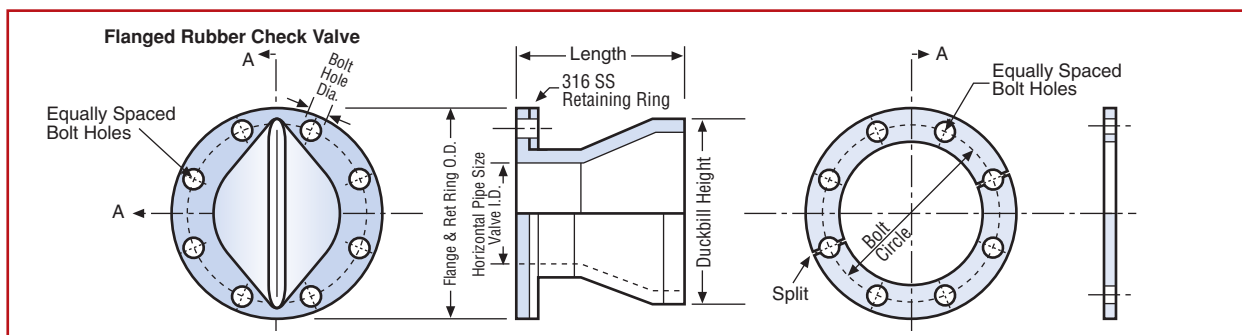

Handy Bits

Temperature

Degrees Fahrenheit	(degrees Celsius x 1.8) + 32
Degrees Celsius	(degrees Fahrenheit-32) / 1.8

Length

1 inch	25.4 millimetres	
1 millimetre	0.0393701 inches	
1 foot	0.3048 metre	
1 yard	36 inches	0.9144 metre
1 league	3 nautical miles	5.556 kilometres
1 fathom	6 feet	1.8288 metres
1 mile	1.609344 kilometres	0.86897624 nautical mile
1 nautical mile	1.852 kilometres	1.150779448 miles
1 metre	39.37 inches	1.09361330 yards
1 kilometre	0.62137119 mile	0.53995680 nautical mile

Speed

1 knot	1.852 kilometres per hour	1.15077945 miles per hour
1 kilometre per hour	0.62137119 mile per hour	0.53995680 knot
1 mile per hour	1.609344 kilometres per hour	0.86897624 knot

Volume

1 fluid ounce	29.57353 millilitres	
1 quart U.S.	32 fluid ounces	0.9463529 litre
1 gallon U.S.	3.785412 litres	
1 litre	0.2641721 gallon	
1 cubic foot of seawater	64 pounds	29.03 kg
1 cubic foot of freshwater	62.428 pounds	28.317 kg
1 cubic foot of ice	56 pounds	25.41 kg

Weights

1 ounce	28.349523125 grams
1 pound	0.45359237 kilogram
1 kilogram	2.204623 pounds

Area of a circle= Diameter squared x .7854

Miles to Kilometres: Miles multiplied by 1.609344

Kilometres to Miles: Kilometres multiplied by .62137119

Index

Ring Mount Floodgates 100 - 900	2
Ring Mount Floodgates 1050 - 1800	3
Low Head Floodgate (Ring Mount) 100 - 900	4
Wall Mount Floodgate 100 - 900	5
Wall Mount Floodgate 1050 - 1800	6
Integrated Security Bars.....	8
Bolt on Top of Pipe Series Floodgate 1050 - 1800.....	9
Low Internal Head Floodgate (Bolt on Type) 100 - 900	10
100 - 375 Suit Scour Application	11
Performance Data	13
Small Box Culvert Floodgate.....	14
Large Box Culvert Floodgate	15
Rubber Duckbill Check Valves (Clamp On).....	16
Rubber Duckbill Check Valves (Flanged).....	18
Handy Bits.....	20

Warranty

- Warranty. Prime Composites Australia warrants to the Customer that its manufactured floodgate product line ("Goods") is reasonably fit for the purpose described in the Prime Composites Australia catalogue and free of defects ("the warranty").
 - Prime Composites Australia shall not be liable for a breach of the warranty unless:
 - The Customer gives written notice of the defect to Prime Composites Australia within 10 business days of delivery if the defect is as a result of damage in transit to the carrier or within 10 business days of discovery by the Customer if discovered within 12 months of installation or 15 months from date of delivery (whichever is earlier); and
 - Prime Composites Australia is given a reasonable opportunity after receiving the notice to examining such products and the Customer (if asked to do so by Prime Composites Australia) returns such products to Prime Composites Australia's place of business for the examination to take place there.
 - Prime Composites Australia shall not be liable for a breach of the warranty if:
 - The Customer continues to use the products after giving such notice; or
 - The defect arises because the Customer did not follow Prime Composites Australia's oral or written instructions as to the storage, installation, commissioning, use or maintenance of the products; or
 - The Customer alters or repairs such Goods.
 - Subject to the limitations of Clauses 1(a) and 1(b), if any of the products do not conform with the warranty in Clause 1, Prime Composites Australia shall at its sole option:
 - Repair or replace such Goods (or the defective part); or
 - Refund the price of such Goods provided that, if Prime Composites Australia so requests, the Customer shall return the Goods or the part of such Goods which is defective to Prime Composites Australia.
 - If the products delivered are not what the Customer ordered or are damaged or defective or the delivery is of an incorrect quantity, Prime Composites Australia shall have no liability to the Customer unless the Customer uses reasonable efforts to notify Prime Composites Australia in writing at Prime Composites Australia's contact address of the problem within 15 working days of the delivery of the Goods.
 - The Customer shall notify Prime Composites Australia within 30 days of the date on which an Order is scheduled to be delivered, if such delivery is not made. In the event the delivery is not made, and the Customer does not otherwise notify Prime Composites Australia, no liability or obligation of any sort shall arise on the part of Prime Composites Australia to the Customer for any direct or indirect loss or damage. Regardless of notice, the Customer's remedies shall be strictly limited to delivery of such product or refund of monies with selection of such relief to be at the sole discretion of Prime Composites Australia and Prime Composites shall be not otherwise be liable for any direct or indirect loss or damage to the Customer. The Customer acknowledges that delivery dates are estimates only and Prime Composite Australia accepts no liability for delays in delivery.
 - The Customer acknowledges that, except as aforesaid and otherwise required by law, Prime Composites Australia is not liable for any cost, expenses, loss or damage of whatsoever nature, whether direct, indirect or consequential, caused by or resulting from breach of any conditions or warranty.
 - If any term of this Warranty is determined by a court to be invalid, unlawful or unenforceable to any extent, such term, condition or provision will to that extent be severed from the remaining terms, conditions and provisions which will continue to be valid to the fullest extent permitted by Law.
- Transfer of Title. Until the Goods are paid for in full, the title remains with Prime Composites Australia, which shall have all rights to register a security over such Goods.
- Return/Cancellation Policy. The Customer acknowledges the uniqueness of the Goods manufactured by Prime Composites Australia and recognises that no refunds or cancellations of Orders shall be permitted.
- Jurisdiction. The Agreement shall be deemed to have been entered into in the State of Queensland and the Customer agrees to submit to the exclusive jurisdiction of the courts of that State.

Disclaimer

Whilst all care is taken in the preparation of this product catalogue, Prime Composites will not be responsible for any errors or omissions contained within.

Prime Composites Aust P/L

ARE YOU PREPARED TO RISK THE ALTERNATIVE?

Unit 43/38 Kendor Street Arundel Queensland 4214
Tel: 61 07 5500 5300 • Fax: 61 07 5500 5311
sales@primecomposites.com.au • www.primcomposites.com.au